



PROCESS CONTROL SYSTEMS, INC.

327 LAKE HAZELTINE DRIVE, CHASKA, MN 55318

952-361-3026

(Fax) 952-368-4129

800-328-0738

MAXIGARD™



A1100 AND A1200 SPEED SWITCHES



Introduction

The MAXIGARD A1100 and A1200 are fail safe devices designed to monitor the rotation of critical driven shafts. They are precision built of quality material and completely factory tested to insure long life and trouble free operation.

Principle of Operation

While the shaft (with magnet disc or wrap attached) is rotating, a 0-3 Volt AC signal is generated and picked up by the sensing head. This signal is not impaired by build up of dust or any other foreign material on the magnet disc or sensing head. The signal is processed through an electronic circuit and energizes the relays. The relays have DPDT contacts.

A1100 Single Set Point

The A1100 is designed to detect an unauthorized slow down, stoppage or over speed of the monitored shaft. The A1100 has one adjustable trip point relay and has a built in time delay of 5 seconds. Delay activates on start up only. The relay is DPDT. The set point is designed fail safe. Should there be a power failure, loss of signal, component failure etc., the relay will de-energize and put the switch in alarm condition.

A1200 Dual Set Point

The A1200 is designed to detect over speed, under speed, slow down or stoppage of the monitored shaft. It has two adjustable trip point relays. The low set point relay (K1) has a built in time delay of 5 seconds. Delay activates on start up only, the relays are DPDT. Each trip point is designed fail safe. If there is a power failure, loss of signal, component failure etc., the relay will de-energize and put the system into alarm condition.

The speed switches have automatic resetting, when the alarm condition ceases and the speed returns past the preset trip point, the relays(s) will energize and allow the machine or process to restart and operate as normal. However, in some cases it is desirable that the relay(s) remain in the alarm condition regardless of the signal being received, requiring a manual reset. The standard relays can be equipped to perform this latching function. Consult factory for latching instructions.

Components

THE A1100 AND A1200 SWITCH PACKAGES INCLUDE:

- 4" MAGNET DISC
- MOUNTING BRACKET
- UL/CSA LISTED NEMA 4 ENCLOSURE
- SENSING HEAD W/10' OF CABLE
- SPEED SWITCH CIRCUITRY

CALL TOLL FREE  800-328-0738

www.maxigard.com

E-mail: techsupport@maxigard.com

SECTION 1 - MECHANICAL

1.0 Magnet Disc

- 1.1 The end of the shaft to be monitored should be square to prevent excessive disc wobble.
- 1.2 Center drill and tap the shaft end. (Suggested #21 drill and #10-32NF tap). Bolt the magnet disc to the end of the shaft. Use "Loc-tite" to keep the bolt and disc tight on the shaft.
(see figure 1B, page 3).

2.0 Magnet Wrap (optional)

- 2.1 Separate the two halves of the magnet wrap by loosening the cap screws holding the two halves together.
- 2.2 Place both halves of the magnet wrap around the shaft. Re-insert and tighten the cap screws making sure the wrap is square to the shaft.
(see figure 1A, page 3).

NOTE

There will be a slight gap between the two halves after tightening. This gap will not affect the generated signal.

3.0 Mounting the Sensor

- 3.1 Place the sensor so that the pole piece is centered directly in front of the magnets in the disc or optional wrap.
(see figure 1A & 1B, page 3).
- 3.2 The gap setting between the pole piece and magnet disc should be approximately 1/8" - 7/8".

SENSING METHOD

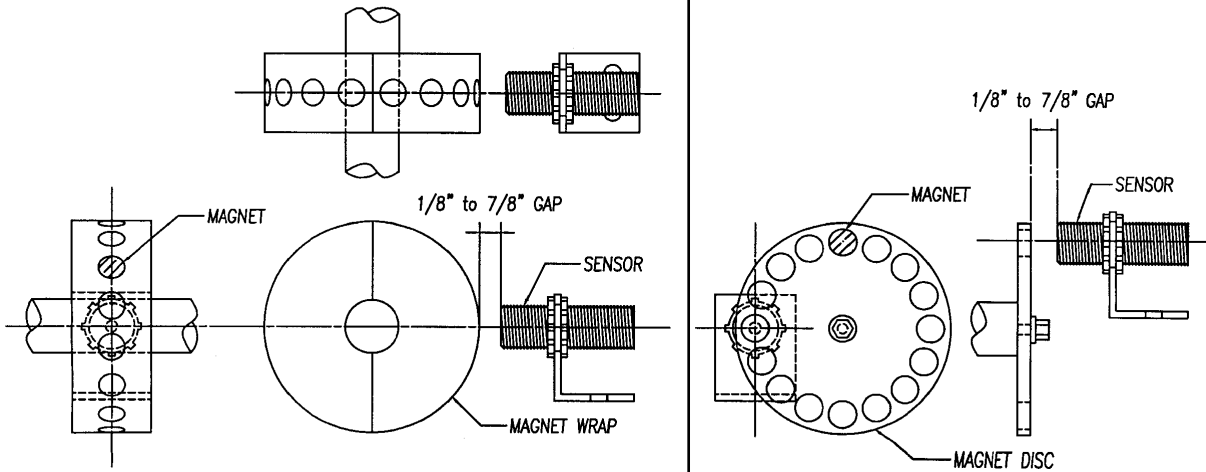

FIGURE 1A

FIGURE 1B

4.0 Speed Switch Enclosure

4.1 A1100 and A1200 enclosures are UL/CSA listed, rated NEMA 4, dust tight, oil tight and water tight steel construction suitable for indoor and outdoor use.
(see figure 2, page 3)

CAUTION
Remove the circuit board from the enclosure before punching or drilling conduit holes. Be sure to remove all metal chips and fillings.

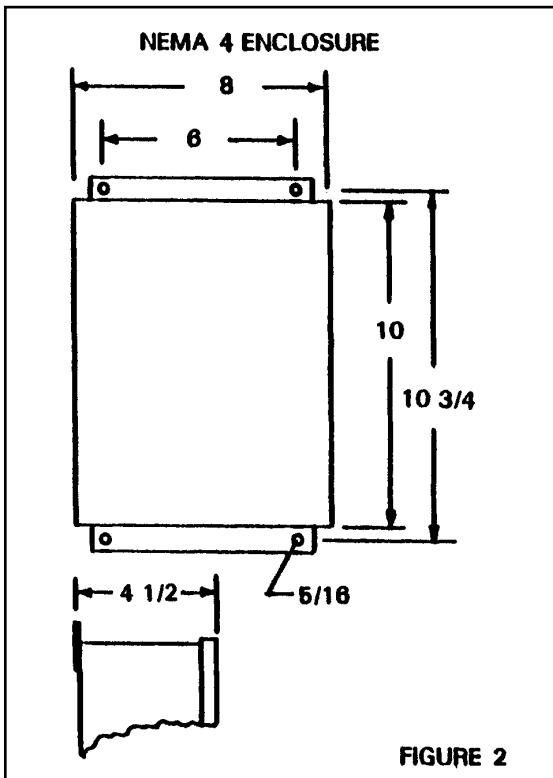

FIGURE 2

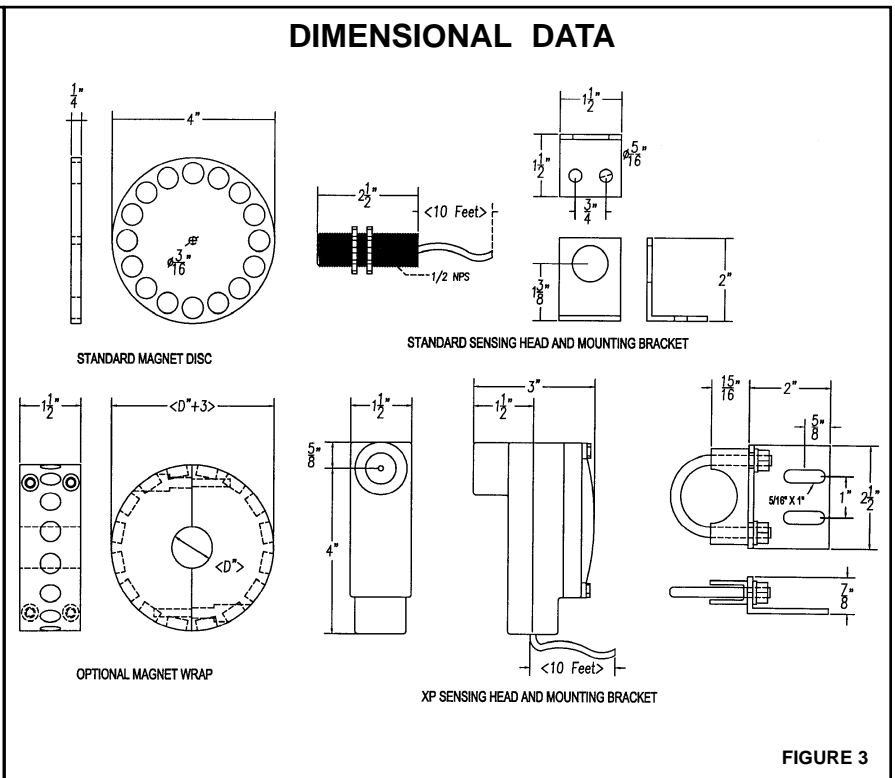

FIGURE 3

SECTION 2 - FIELD WIRING

5.0 Wiring

NOTE

See "wiring Guide supplement", part of these instructions (pages 13 & 14).

5.1 Sensor Wiring

- 5.1.1 Connect the sensor cable to terminal block TB2, terminals 1, 2, 3, located on the circuit board.
(see figure 4, page 5)
- 5.1.2 The sensor comes standard with 10' of cable, if additional cable is required, be sure to maintain continuity.

SENSING HEAD CABLE

Use "Belden" #8761 or equal. Cable should not be run in same conduit as power lines. Maximum distance of cable run 10,000'. Make good splice connections and check continuity.

5.2 Connecting Power

WARNING

Be sure that line voltage is off before connecting power.

SEPARATION OF CIRCUITS

Field installed conductors in this enclosure, connected to TB1 shall maintain a 2 inch minimum spacing between conductors connected to TB2, and shall be segregated from uninsulated live parts.

- 5.2.1 Apply 120 or 240 Volts AC power to terminal block TB1, terminals 1, 2, 3, 4.
(see figure 4, page 5)
- 5.2.2 Connect equipment grounding conductor to the ground terminal provided on the enclosure sub-panel.
(see figure 4, page 5)

- 5.2.3 Do not bundle any low level signal wires with the power wires. This will keep any potential noise interference at a minimum.
- 5.2.4 Power for the speed switch can be applied through motor starter auxiliary contacts.

WARNING
 To avoid electrical shock, disconnect all sources of power to the motor starter before wiring and observe voltage ratings of the speed switch.

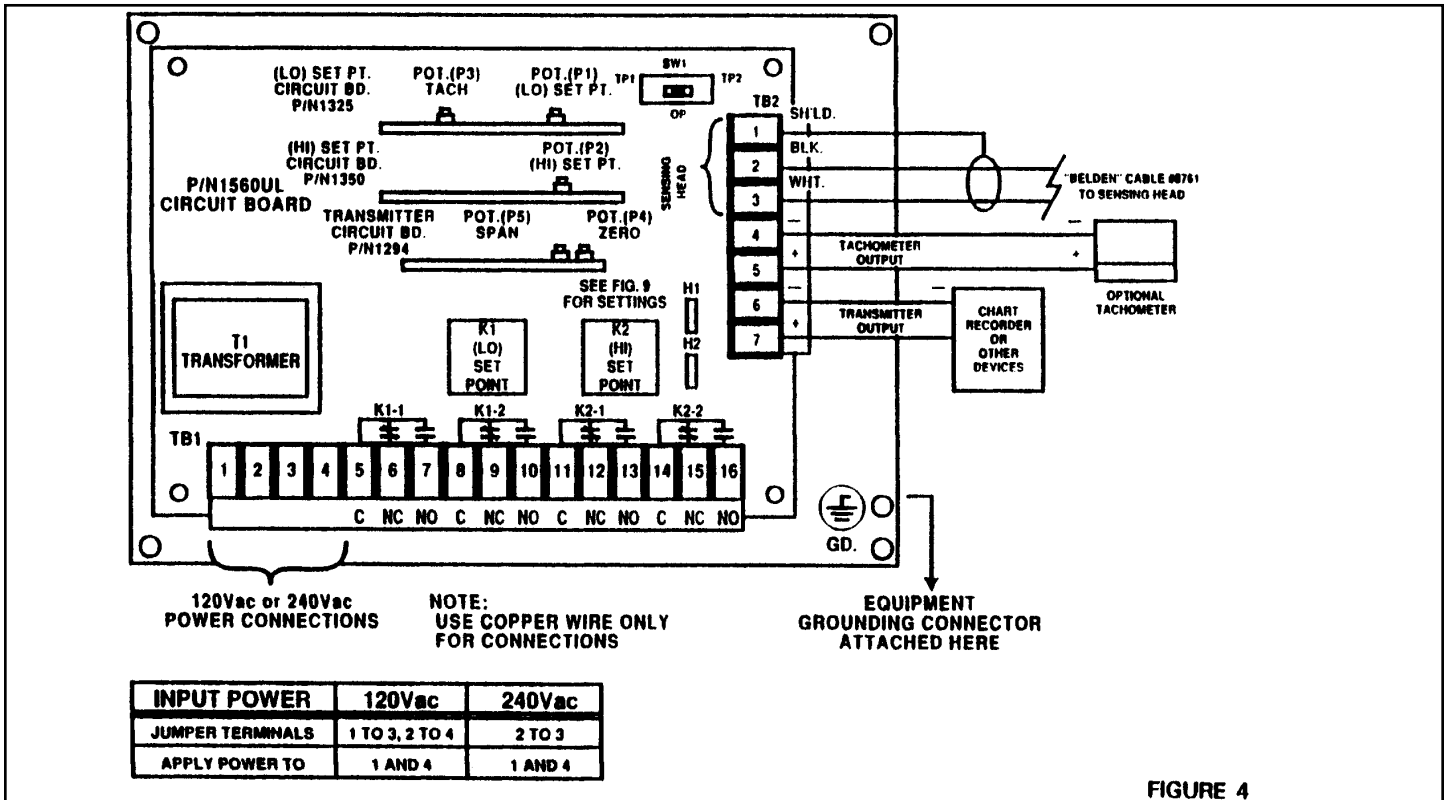

FIGURE 4

5.3 Speed Switch Relays

NOTE
 The A1100 and A1200 motion switches low set point relay (K1) has a built in time delay of 5 seconds. Delay activates on start up only.

- 5.3.1 The speed switch can be wired to detect slow downs, stopping, starting, over speed and/or under speed.
- 5.3.2 DPDT relay contacts are available for each set point. Refer to the specifications for contact ratings.
(see page 11 of these instructions)

6.0 Speed Range Selection

6.1 Set dip switch for speed range.
(see figure 5, page 6)

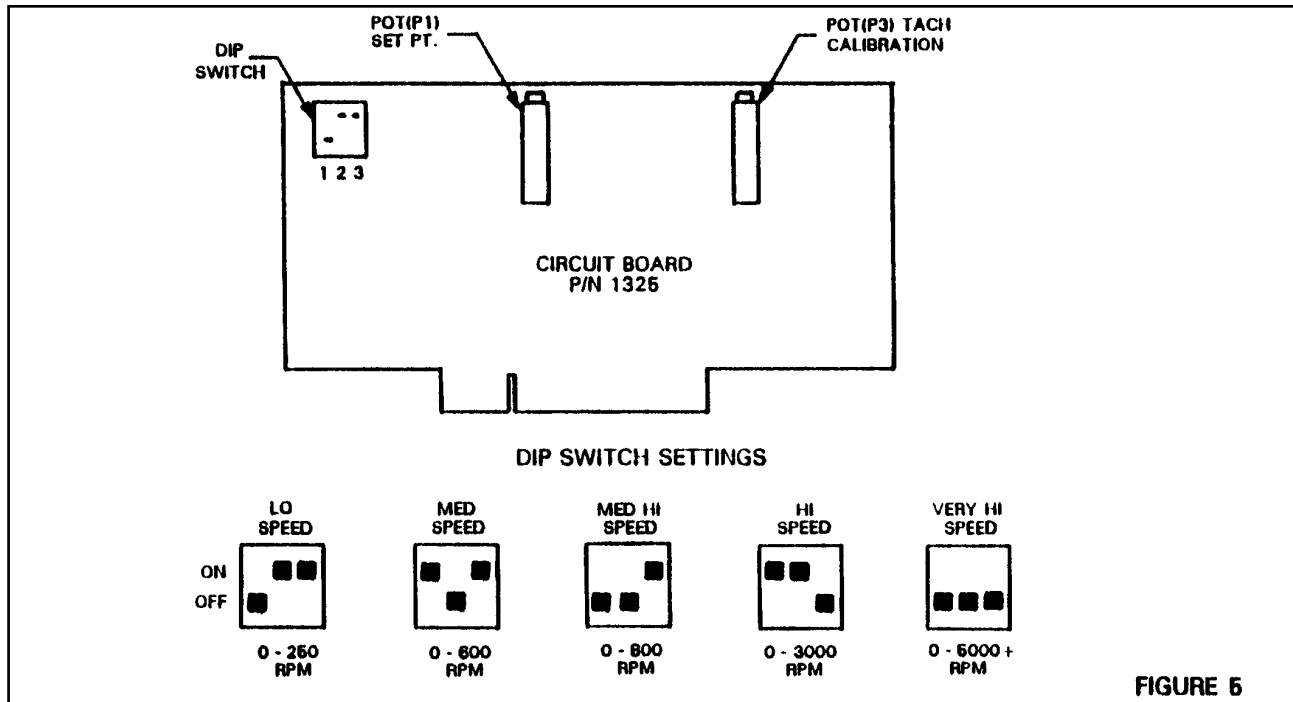

FIGURE 5

7.0 Switch and Optional Meter Calibration

NOTE

For best results calibrate meter while machine is running under full load.

7.1 Connect power as described in section 5.2.

7.2 Run machine that you are monitoring and determine speed of monitored shaft. A hand held tachometer is suggested.

7.3 Power "ON" move slide switch to the OP position and turn POT P3 (C. W. to decrease) reading, (C.C.W. to increase). Match the readout on the meter with the speed of the monitored shaft.
(see figure 6, page 7)

NOTE

If an optional tachometer is not used or is inoperable, a voltmeter set on low range (2 Volt DC) can be used to calibrate the speed switch. Attach the voltmeter leads to meter output connections on terminal block TB2, terms, 4(-) and 5(+). The voltmeter scale will display the machine speed in a percentage of the meter scale.
(see figure 4, page 5)

EXAMPLE

When the full operating speed is reached, calibrate POT P3 until the voltmeter reads 1/2 Volt DC = full scale range. A 1/4 volt reading when calibrating the set point(s) would equal a 50% drop from 100% operating speed. When the slide switch is in the TP1 or TP2 position, the voltmeter should read a percentage of the 1/2 volt full scale range.
(see figure 6, page 7 , and figure 7 and 8, pages 8 and 9)

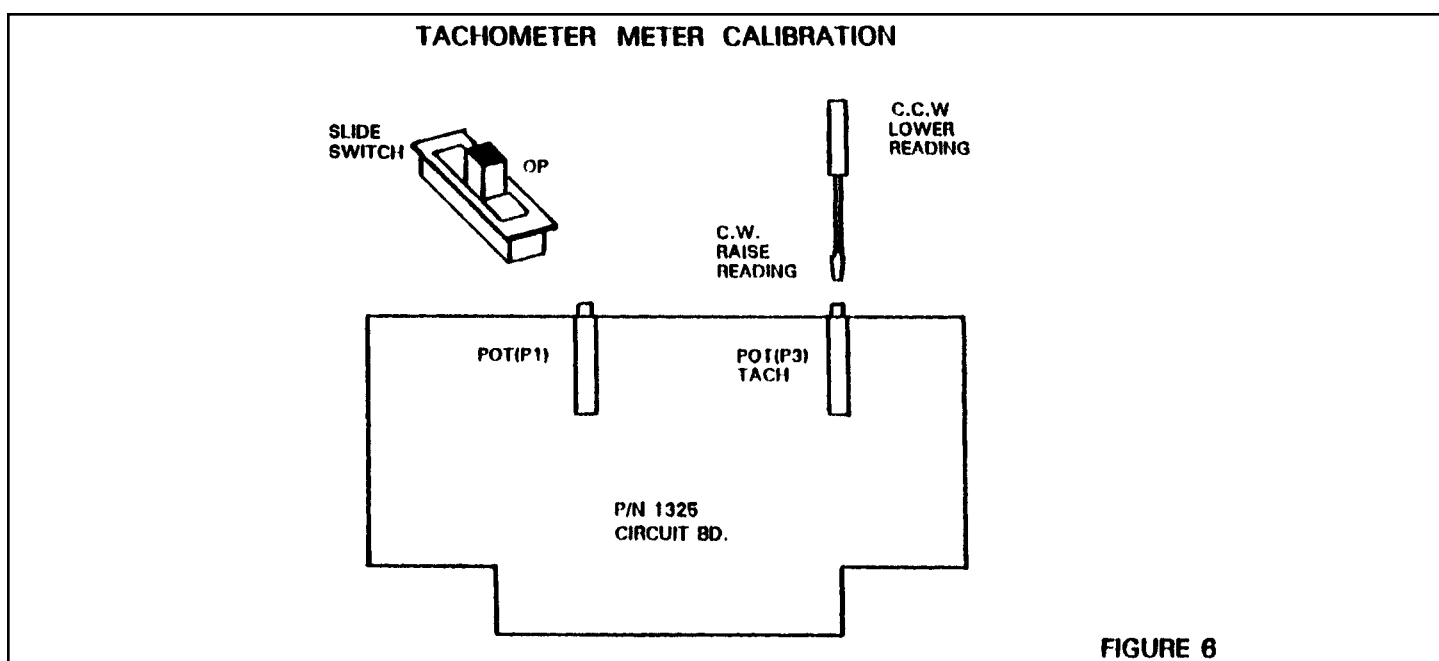
**8.0 Low Trip Point Adjustment, (K1) A1100, A1200****NOTE**

Machine does not have to be running to adjust set point. However, for best results it is suggested these adjustments be made while machine is running under full load.

NOTE

The A1100 and A1200 speed switches low set point relay (K1) has a time delay of 5 seconds. Delay activates on power up only.

- 8.1** Move the TP slide switch to TP-1 position and adjust POT P1 to desired trip point by watching indicating meter pointer. Turning POT (C.W. to increase), (C.C.W. to decrease).
(see figure 7, page 8)
- 8.2** Return the TP slide switch to the operate position (OP). The Motion Switch is now calibrated with trip point set and ready for operation.

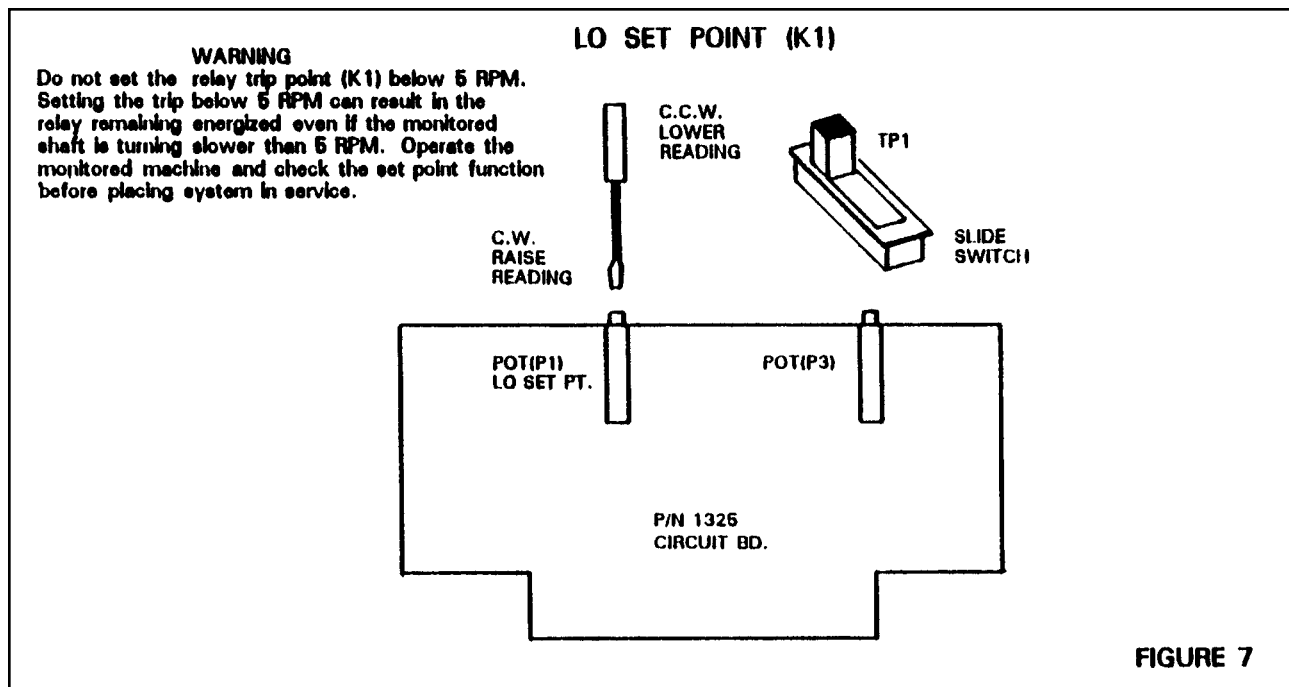

9.0 “HI” Trip Point Adjustment (K2) A1200

- 9.1** Move the slide switch to the TP2 position and adjust POT P2 to desired trip point by watching the meter pointer. Turning the POT (C.W. to increase), (C.C.W. to decrease).
- 9.2** Return the slide switch to the Operate position. The motion switch is now calibrated. The trip points are set and ready for operation.

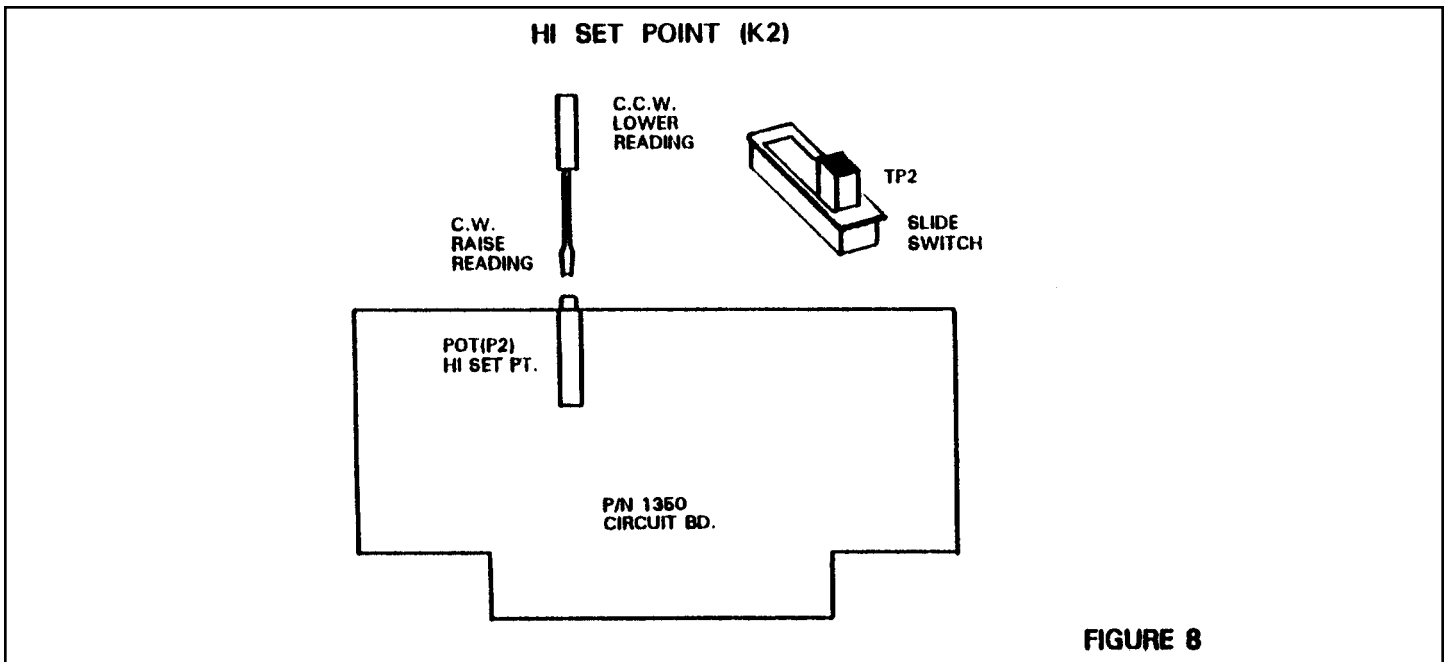

10.0 Signal Calibration 4/20 mA or 0-10 VDC outputs (optional)
 (see figure 9, page 9 & figure 10, page 10)

The Signal Transmitter has been calibrated and factory tested (as accurately as possible) to match your operating speed and output requirements. However, final calibration will be required during installation and start up. This final calibration is made by adjusting the zero and span pots.

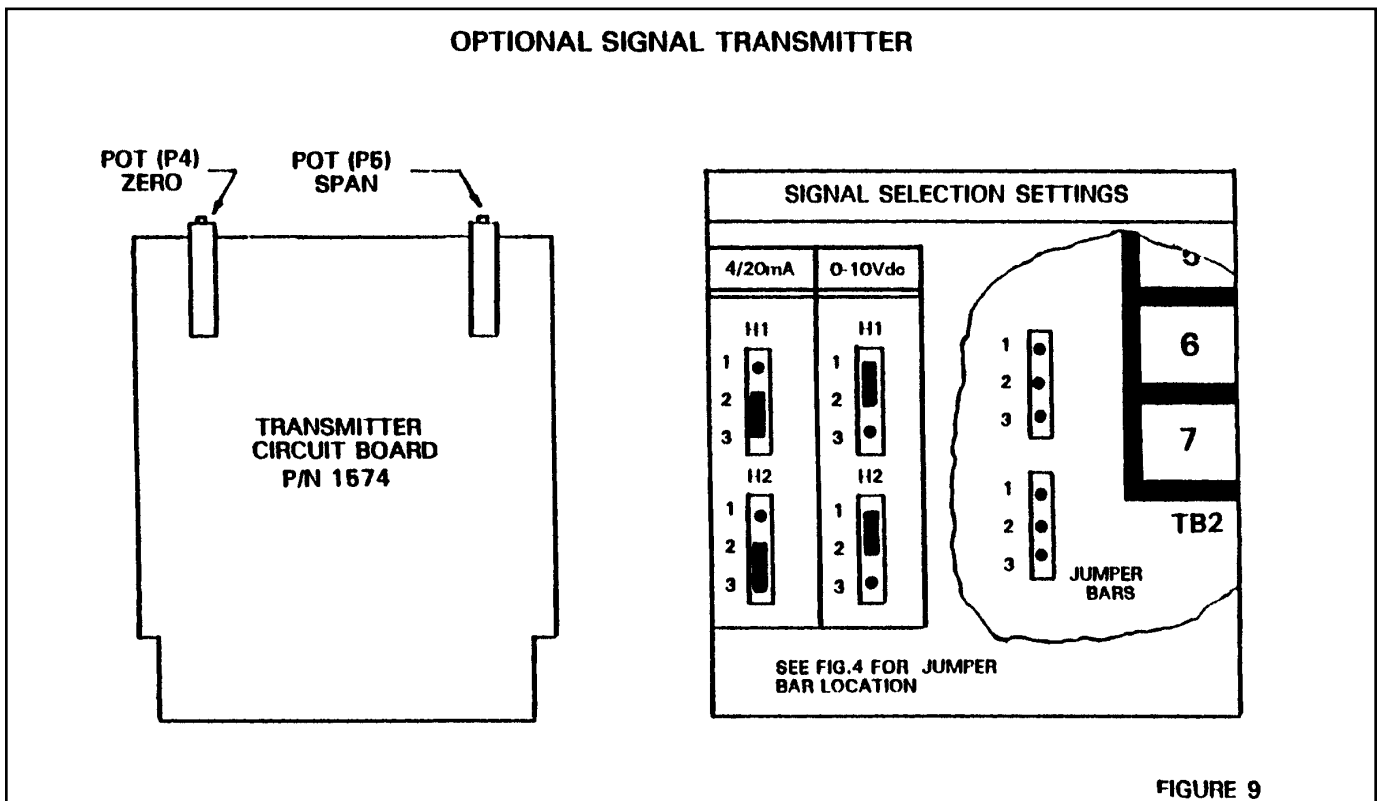

Before adjusting the zero and span pots, select the speed range as shown in figure 10, page 10.

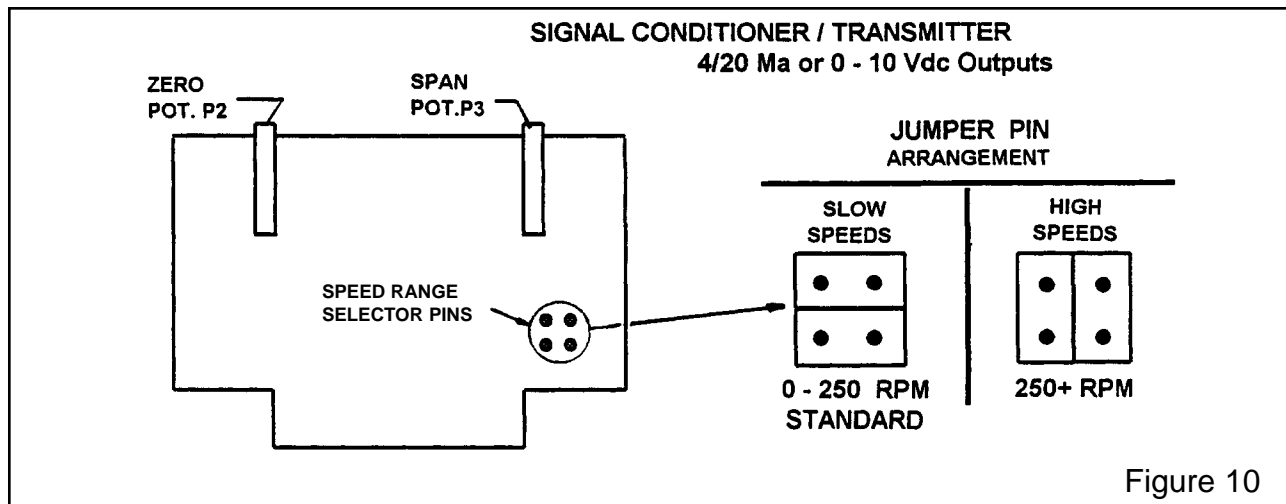

Figure 10

10.1 4/20 mA Output

10.1.1 Set meter to the milli-amp current scale adequate for 4/20 mA calibration.

10.1.2 Connect voltmeter positive and negative leads to terminal block TB2 term. 6(-), term. 7(+).

10.1.3 Turn on power to circuit and with monitored machine at -0- speed turn "Zero POT" (C.W. to increase) and (C.C.W. to decrease), until voltmeter indicates "4 mA".

10.1.4 With power on and monitored machine running at full speed, turn "Span POT" (C.W. to increase) and (C.C.W. to decrease), until voltmeter indicates "20 mA".

10.2 0-10 VDC Output

To calibrate the system accurately, use a voltmeter as follows:

10.2.1 Set voltmeter to the DC voltage range adequate for 0-10 VDC calibration.

10.2.2 Connect voltmeter leads to terminal block TB2, term. 6(-), term. 7(+).

10.2.3 Turn on power to Signal Transmitter circuit and with monitored machine at -0- speed, turn "Zero POT" (C.W. to increase) and (C.C.W. to decrease) until voltmeter indicates -0- Volts.

10.2.4 With power on and monitored machine running at full speed, turn "Span POT" (C.W. to increase) and (C.C.W. to decrease), until voltmeter indicates 10 Volts, or to what your system requires.

POWER REQUIREMENTS:

120/240 VAC, 50/60 HZ

POWER CONSUMPTION:

A1100: 5 WATTS, 34 mA @ 120 VAC,
17 mA @ 240 VAC

A1200: 5 WATTS, 44 mA @ 120 VAC,
21 mA @ 240 VAC

ENVIRONMENTAL TEMPERATURE

INFLUENCE: .1% OVER 50°F

OPERATING TEMPERATURE:

32°F TO 140°F

0° TO 60°C

FUNCTIONAL:

SENSOR OUTPUT: ANALOG, 0-3 VAC

@ 0-4.5 MILLI-AMPS, CURRENT

LIMITED

SENSOR GAP: SENSING DISTANCE

BETWEEN MAGNET DISC AND

SENSOR, 1/8" TO 1" (ALTRA-GAP™)

SIGNAL TRANSMISSION

DISTANCE: SENSOR TO CIRCUIT, UP

TO 10,000 FT

OPERATING SPEED RANGE:

5 RPM TO 10,000 RPM

TRIP POINT SETTINGS:

BY MULTI-TURN POTENTIOMETER

RELAY: DPDT - 7 AMP RESISTIVE @

120/240 VAC, 7 AMP @ 24 VDC

(CONTACTS N.O. AT REST)

ACCURACY: ± 2% FULL SCALE

REPEATABILITY: ± .5% FOR

CALIBRATION AND SET POINT
SETTINGS

TIME DELAY: "LO" SET POINT RELAY

(K1) HAS A BUILT IN TIME DELAY OF

(5 SECONDS), DELAY ACTIVATES

ON START UP ONLY.

CONSTRUCTION:

MAGNET DISC: ANODIZED ALUMINUM,

CERAMIC MAGNETS

MAGNET WRAP: (OPTIONAL)

MACHINED ALUMINUM, CERAMIC

MAGNETS, WRAPS ARE BORED TO

FIT SHAFT DIAMETER.

SENSOR: ANODIZED ALUMINUM,

WATER RESISTANT, EPOXY

ENCAPSULATED COMPLETE WITH 10'

CABLE.

SENSOR CABLE: 22 GAUGE, 2 WIRE

SHIELDED "BELDEN" #8761 OR

EQUAL

ENCLOSURE: NEMA 4, UL LISTED AND

CSA CERTIFIED

ELECTRICAL CONNECTIONS:

SCREW TYPE TERMINALS

CIRCUITS: HEAVY DUTY INDUSTRIAL

DESIGN UL LISTED

OPTIONS:

- DIGITAL OR ANALOG TACHOMETER
- TRANSMITTER OUTPUTS: 4/20 mA INTO A 0-500 OHM LOAD OR VOLTAGE 0-10 VDC INTO A 20K OHM LOAD MINIMUM
- MAGNET SPLIT COLLAR WRAPS *
- MAGNET PLATES
- EXPLOSION PROOF SENSOR

RELATED BULLETINS:

- INSTALLATION AND OPERATING INSTRUCTIONS: A211
- PRICING: AP145-1
- FULL LINE CATALOG: A129

NOTE:

* CONSULT FACTORY FOR WRAPS THAT WILL BE TURNING FASTER THAN 3000 RPM

Relay Chart Contact Ratings

UL Ratings								
Voltage (V)	Resistive (A)				General Use (A)			
	SPDT	DPDT	3PDT	4PDT	SPDT	DPDT	3PDT	4PDT
240 AC	10	10	-	7.5	7	7	-	5
120 AC	10	10	10	10	7.5	-	-	7.5
30 DC	10	10	10	-	7	7	-	-
28 DC	10	10	10	10	7.5	-	-	7.5

Note: *8.5 A/Pole, 20A Total

CSA Ratings								
Voltage (V)	Resistive (A)				General Use (A)			
	SPST	DPDT	3PDT	4PDT	SPDT	DPDT	3PDT	4PDT
240 AC	10	10	-	7.5	7	7	7	5
120 AC	10	10	10	10	7.5	7.5	-	7.5
30 AC	10	10	10	10	7	7.5	-	-

UL & CSA Horsepower Ratings		
Motor Load	SPST, DPDT	3PDT
240V AC	1/3 HP	1/3 HP
120V AC	1/6 HP	1/6 HP

Nominal Ratings								
Voltage (V)	Resistive (A)				Inductive (A)			
	SPST	DPDT	3PDT	4PDT	SPDT	DPDT	3PDT	4PDT
220 AC	7	7.5	7.5	4.5	5	5	5	5
110 AC	10	10	10	10	7	7.5	7.5	7.5
30 AC	10	10	10	10	7	7.5	7.5	7.5

Note: Inductive load cos φ = 0.3. L/R = 7msec

TYPICAL MOTION SWITCH WIRING DIAGRAMS

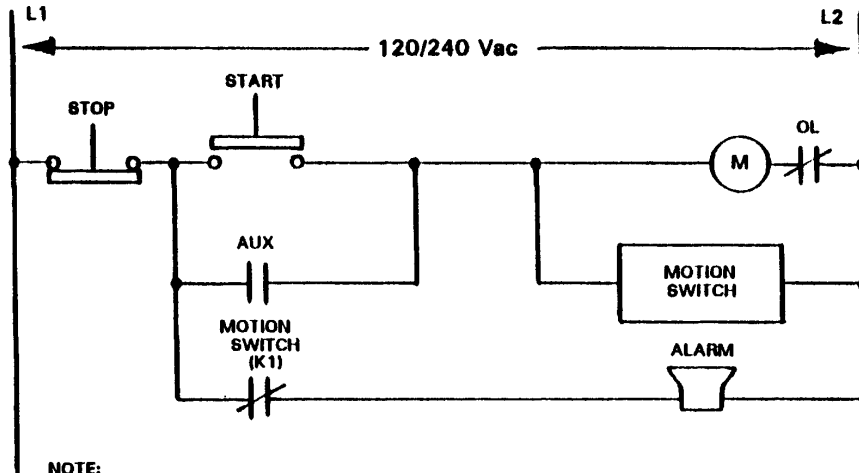

NOTE:
THE A1000/A2000 MOTION SWITCH'S "LO" SET POINT RELAY (K1) HAS A BUILT IN TIME DELAY OF (6 SECONDS). DELAY ACTIVATES ON START UP ONLY.

WIRING DIAGRAM A

When the motor is started, the motor starter auxiliary contacts close. If the monitored shaft is rotating at proper speed, the motion switch relay contacts open. Should there be an unauthorized slow down or stoppage of the monitored shaft, the speed switch relay contacts will then close, energizing the alarm and/or interlocking circuits.

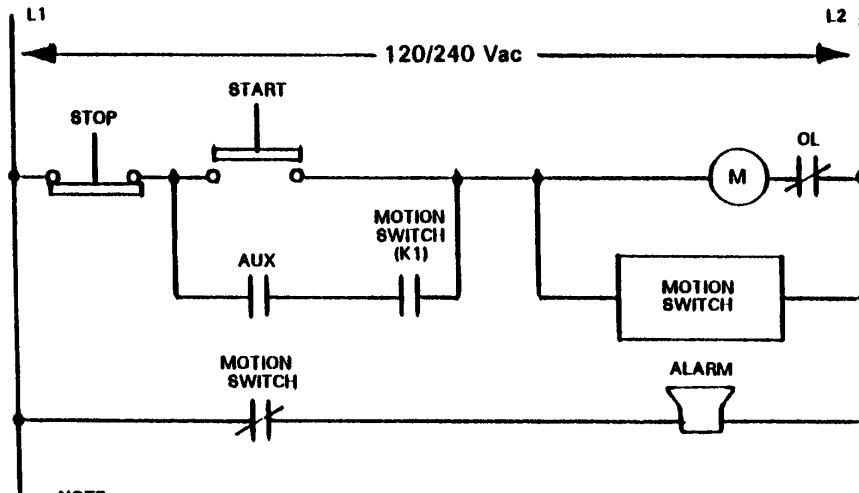

NOTE:
THE A1100/A1200 MOTION SWITCH'S "LO" SET POINT RELAY (K1) HAS A BUILT IN TIME DELAY OF (6 SECONDS). DELAY ACTIVATES ON START UP ONLY.

WIRING DIAGRAM B

When the motor is started, the motor auxiliary contacts close. The motion switch relay (K1) is energized initially for approximately 5 seconds. If the monitored shaft rotates at the proper speed (K1) will remain energized holding in the motor circuit and preventing an alarm condition.

WIRING GUIDE SUPPLEMENT

Wiring guidelines

These guidelines are a tool to use in avoiding potential electromagnetic interference (EMI) problems. They are not a substitute for the wiring practices called out in the National Electrical Code or applicable local codes.

Conductor types

All conductors connected to TB1 or TB2 on the A1100/A1200 must be copper. Two types of conductors are used:

Type 1 conductors

Type 1 conductors are higher power conductors that are more tolerant to electrical noise. They are connected to TB1 and include:

- AC power lines
- Set point relay contact connections

Type 2 conductors

Type 2 conductors are lower powered conductors that are less tolerant to electrical noise. They are connected to TB2 and include:

- The speed switch sensor cable
- The tachometer output cable
- The transmitter output cable

Raceways

The following are general guidelines for routing cables and wires when you install the A1100/A1200. The guidelines apply to cable and wire routing both inside and outside the enclosure.

- Wire and raceways must conform to the National Electrical Code and all applicable local codes and practices.
- Type 1 conductors can be routed with power conductors up to 600 VAC. All conductors in the same raceway must be insulated for the highest voltage applied to any one of the conductors in the raceway.
- Route type 2 conductors in their own separate raceway.
- Maintain 2 inch minimum spacing between type 1 and type 2 conductors inside the A1100/A1200 enclosure.
- When conductors carrying unlike signal levels must cross, in trays or conduits, they should cross at a 90 degree angle with maximum spacing.
- Type 2 conductors should not be routed near contactors, motors, generators, radio transmitters, transformers, rectifiers, arc welders, 480 VAC power lines. Three foot separation should be maintained.

Conduit entries to the A1100/A1200 enclosure

Figure 11 illustrates conduit entry areas for type 1 and type 2 conductors. Figure 12 illustrates recommended conduit and fitting arrangement for wet NEMA 4 locations.

Grounding

Grounding is important for safety in electrical installations. Proper grounding helps reduce the effects of electrostatic and electromagnetic interference. The National Electrical Code gives the requirements for safe grounding. Article 250 provides information about the size and types of conductors and methods of grounding electrical equipment.

The equipment grounding conductor to the A1100/A1200 connects to the terminal marked on the chassis.

Shielded cables connected to TB2 should have their shields connected to TB2-1. Shields should only be grounded at the A1100/A1200 end of the cable to prevent ground loops.

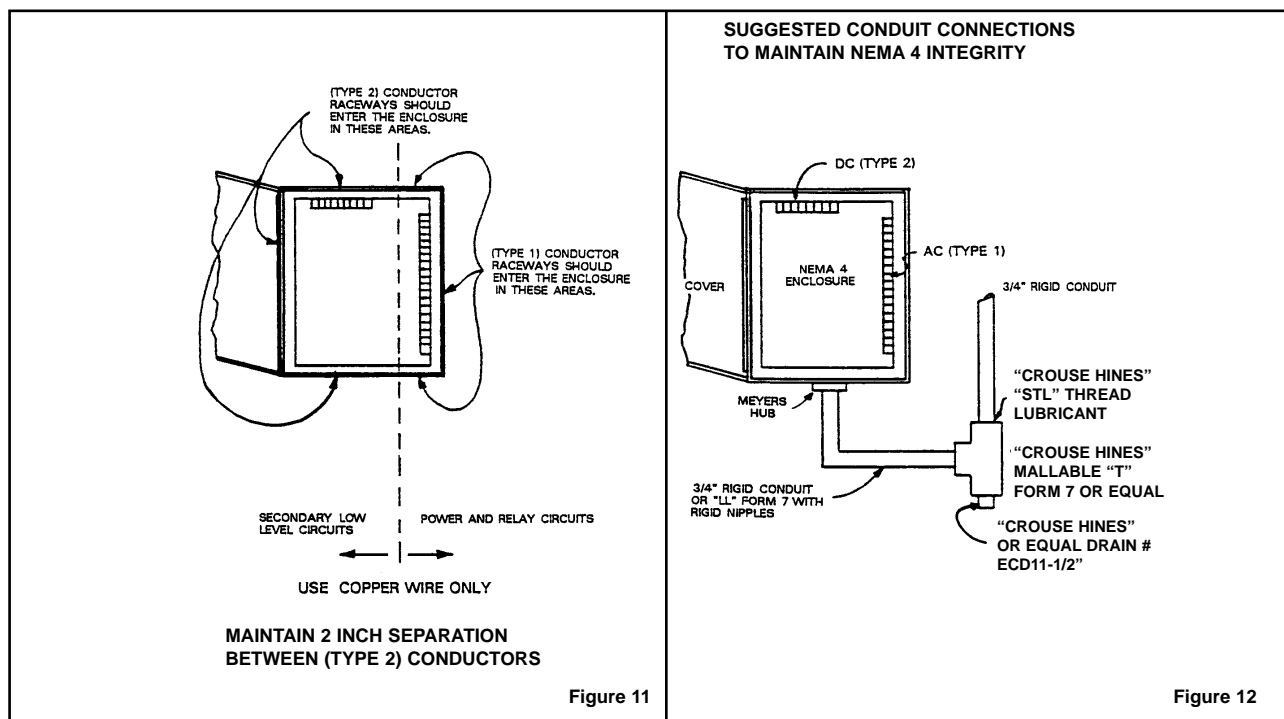

1. Separation of Circuits - field installed conductors in this enclosure, connected to TB1 shall maintain a 2 inch minimum spacing between conductors connected to TB2 and shall be segregated from uninsulated live parts, film-coated and/or printed wire conductors on printed wiring boards. See service manual and wiring guide for details.
2. Use copper conductors only in this enclosure
3. More than one disconnect switch may be required to de-energize the equipment before servicing. See manual for more details.
4. Remove printed wiring board chassis from enclosure before punching, and drilling hub or conduit holes. Be sure to file all sharp edges and remove all metal chips and fillings before installing chassis.

SPARE PARTS LIST

Part No.	Description
1560UL	Circuit Board, Power Supply W/O Relays
1325UL	Circuit Board, Set Point Card #1 (LO)
1350UL	Circuit Board, Set Point Card #2 (HI)
1574	4/20 or 0-10 VDC Output
1129	Sensing Head W/10' Cable (Std) Analog
1130	Mounting Bracket and Jam Nuts (Std)
1132	Sensing Head, W/10' Cable (XP) Analog
1134	Mounting Bracket (XP)
1136	Magnet Disc 4" Diameter
1378	Magnet Disc 8" Diameter
1569	Relay, DPDT - 12 VDC
1139	Cable, Sensing Head, 2 Wire
1177	Meter, Tachometer (Analog)
1324	Meter, Tachometer (Digital) 3-1/2 LED

LIMITED WARRANTY

Process Control Systems, Inc. will repair or replace, at their option, F.O.B. factory, any part or unit which proves to be defective in material or workmanship within five years of purchase date, provided that part of the unit was installed and operated as recommended, to be established by examination of the part or unit at the factory. Goods returned under warranty must be shipped prepaid to the factory and accompanied by the serial number, description of defect, order number and date of purchase.

This warranty shall not apply to any Maxigard™ product which shall have been repaired or altered outside of the Process Control Systems factory or has been subject to misuse, negligence or accident.

Process Control Systems, Inc. warrants its products, but not their application, and shall not be liable for any incidental or consequential damages incurred through the use or loss of use of a Process Control Systems product. No representatives or other person is authorized or permitted to make any warranty or assume for this company any liability not strictly in accordance with this guarantee.

There is no further warranty either expressed or implied beyond that set forth herein.