



PROCESS CONTROL SYSTEMS, INC.
327 LAKE HAZELTINE DRIVE, CHASKA, MN 55318

952-361-3026
(Fax) 952-368-4129
800-328-0738

MAXIGARD™



C3000 SIGNAL TRANSMITTER

Introduction

The MAXIGARD C3000 series is designed to convert shaft speed to 4-20 MA or 0-10 VDC analog outputs. The transmitters are built of quality material and completely factory tested to insure long life and trouble free operation.

Principle of Operation

The Maxigard C3000 Signal Transmitter has a non contact sensor and is supplied with a magnetic target. The sensor signal is not impaired by the build up of dust or any other foreign material on the magnetic target or sensing head. The C3000 is designed to convert shaft speed to analog 4-20 MA or 0-10 VDC outputs.

Components

THE C3000 SIGNAL TRANSMITTER INCLUDES:

- 4" MAGNET DISC (OTHER OPTIONAL TARGETS AVAILABLE)
- SENSING HEAD WITH MOUNTING BRACKET & 10 FEET OF CABLE
- CIRCUITRY WITH 4-20 MA OR 0-10 VDC ANALOG OUTPUT
- NEMA 4 ENCLOSURE (C3000) / NEMA 4X ENCLOSURE (C3000C)

CALL TOLL FREE  800-328-0738

www.maxigard.com
E-mail: techsupport@maxigard.com

SECTION 1 - MECHANICAL

1.0 Magnet Disc

- 1.1 The end of the shaft to be monitored should be square to prevent excessive disc wobble.
- 1.2 Center drill and tap the shaft end. (Suggested #21 drill and #10-32NF tap). Bolt the magnet disc to the end of the shaft. Use "Loc-tite" to keep the bolt and disc tight on the shaft.
(see figure 1A & 1C, page 3).

2.0 Magnet Wrap (optional)

- 2.1 Separate the two halves of the magnet wrap by loosening the cap screws holding the two halves together.
- 2.2 Place both halves of the magnet wrap around the shaft. Re-insert and tighten the cap screws making sure the wrap is square to the shaft.
(see figure 1B & 1D, page 3).

NOTE

There will be a slight gap between the two halves after tightening. This gap will not affect the generated signal.

3.0 Mounting the Sensing Head

- 3.1 Place the sensing head so it is centered directly in front of the magnets in the disc or optional wrap.
(see figure 1A, 1B, 1C & 1D page 3).
- 3.2 The gap setting between the sensor and magnet disc should be approximately 1/8" - 7/8".

SENSING METHOD

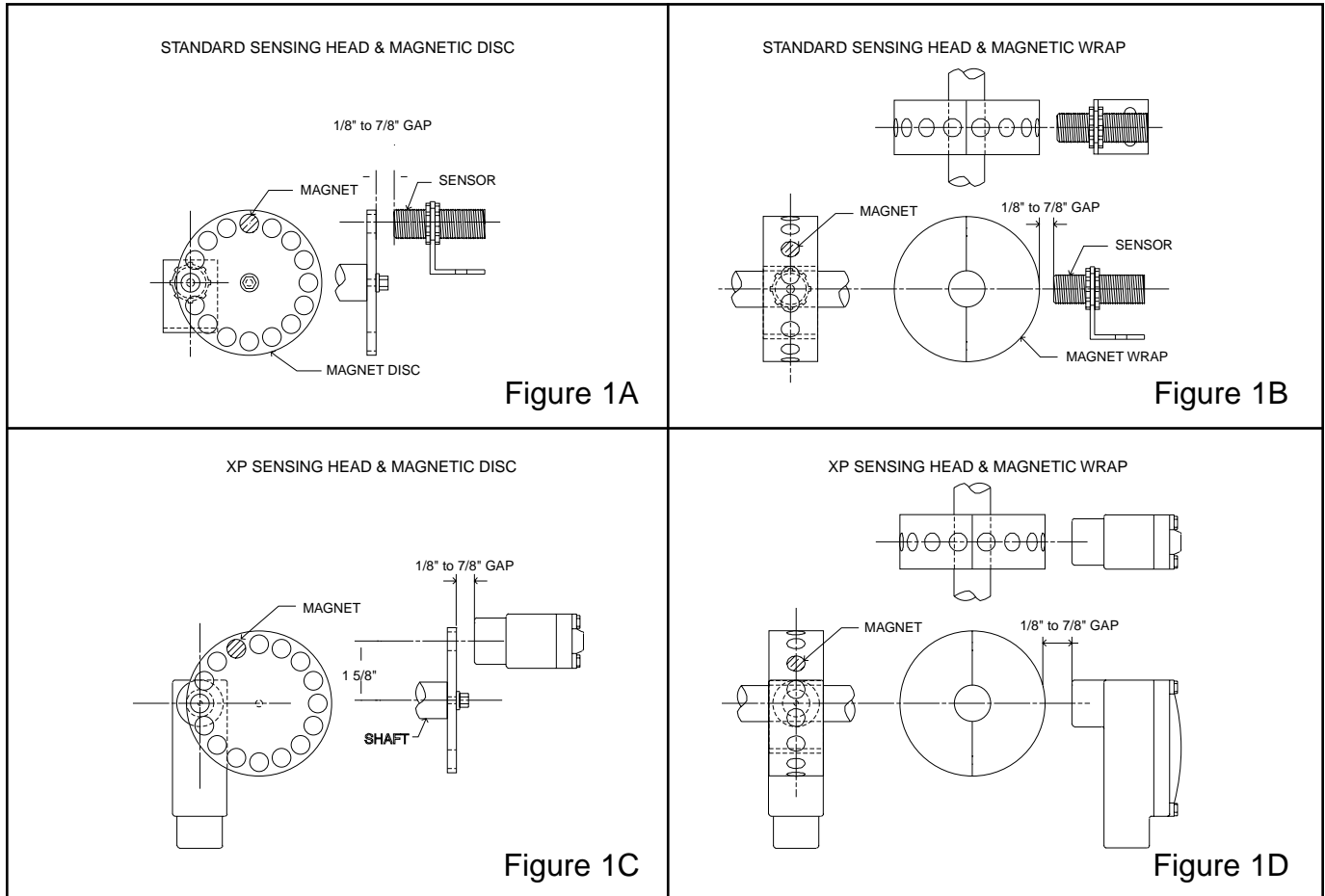

4.0 Signal Transmitter Enclosure

- 4.1** The 3000 switch enclosure is UL/CSA listed, rated NEMA 4, dust tight, oil tight, and water tight, painted carbon steel suitable for indoor or outdoor use.
(see figure 2A, page 4)
- 4.2** The C3000C switch enclosure is UL/CSA listed, rated Nema 4X corrosion resistant, dust tight, oil tight and water tight, fiberglass construction suitable for indoor or outdoor use.
(see figure 2B, page 4)

CAUTION

Remove the circuit board from the enclosure before punching or drilling conduit holes. Be sure to remove all metal chips and filings.

**C3000
NEMA 4 STEEL**

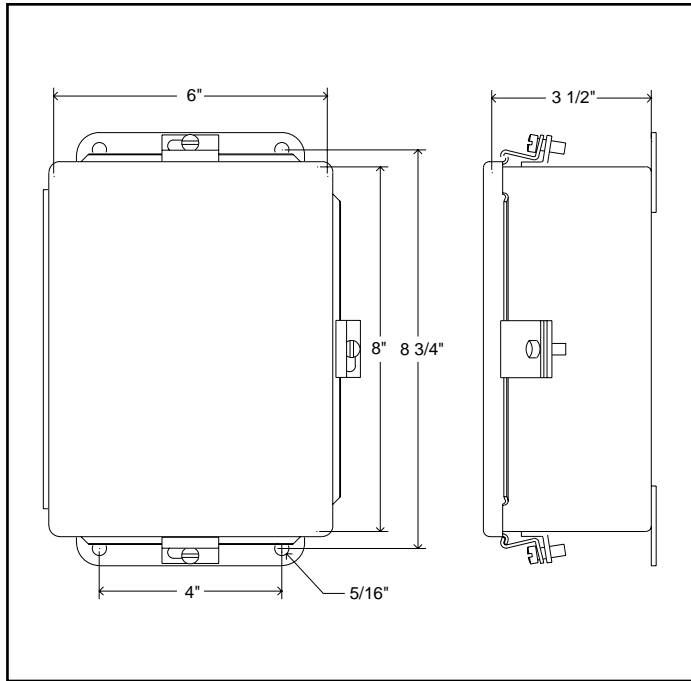

Figure 2A

**C3000C
NEMA 4X FIBERGLASS**

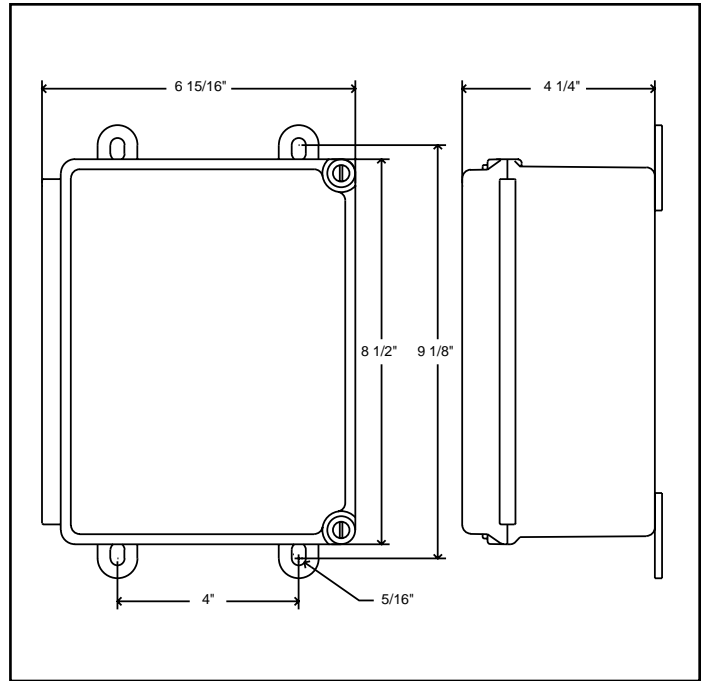

Figure 2B

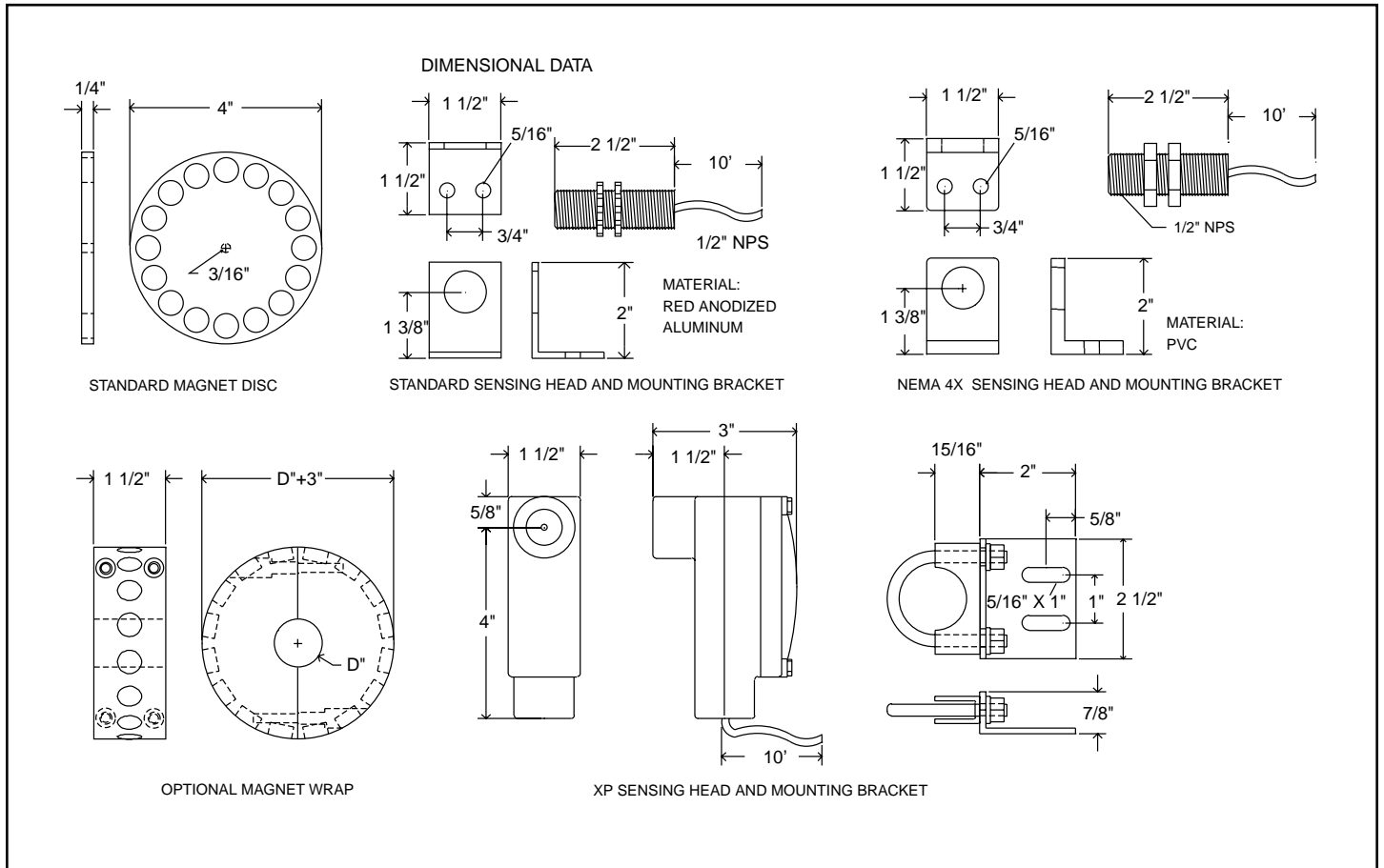

Figure 3

SECTION 2 - FIELD WIRING

5.0 Sensing Head Wiring

- 5.1 Connect the sensing head cable to terminals black, white and shield located on terminal block TB2.
(see figure 4, page 5)
- 5.2 The sensing head comes standard with 10' of cable. Additional cable can be added as required. Be sure to maintain continuity. Wrap the splice with the foil shield and electrical tape.

6.0 Wiring the C3000 or C3000C Signal Transmitter

- 6.1 Connect 120 VAC power to L1 and Neutral to L2 on terminal block TB1. Connect equipment safety ground to GD on terminal block TB1.
(see figure 4, page 5)
- 6.2 Make analog output connections to signal output + - on terminal block TB1.
(see figure 4, page 5)
- 6.3 See figure 5 page 6 for typical wiring interface diagram.

WARNING

To avoid electrical shock disconnect all sources of power before wiring and observe voltage ratings of the C3000 Signal Conditioner.

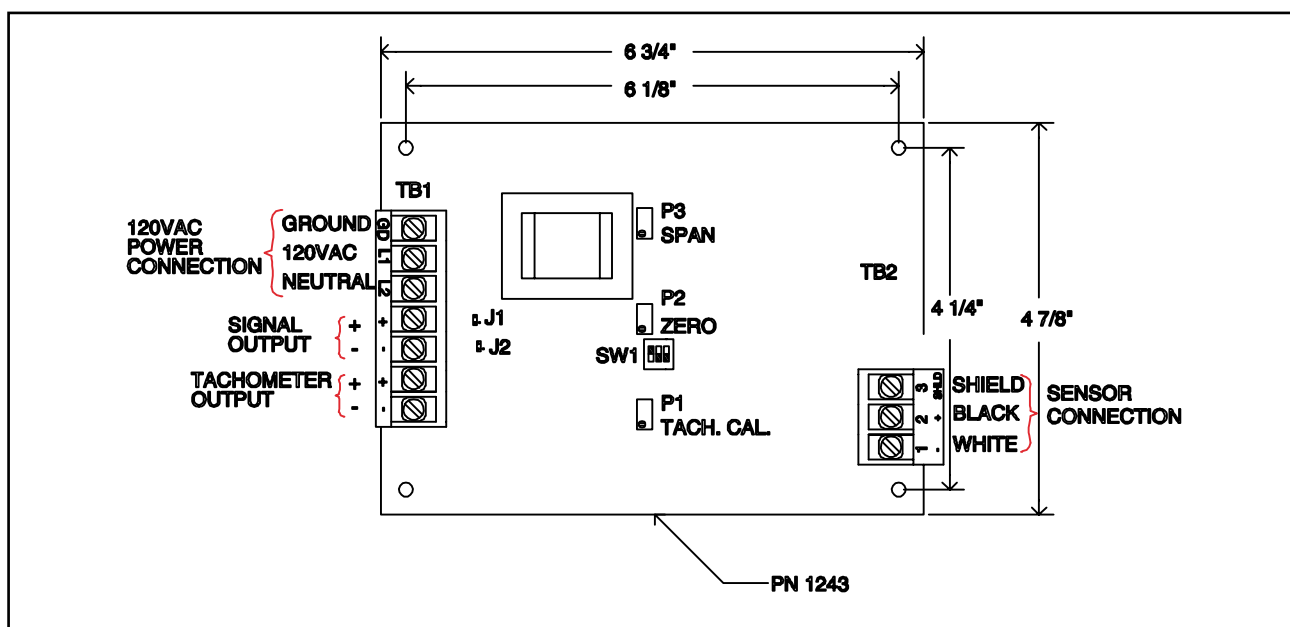

Figure 4

NOTE

The 0-10VDC and 4-20MA outputs must be connected to isolated or differential inputs. Single ended inputs are not supported.

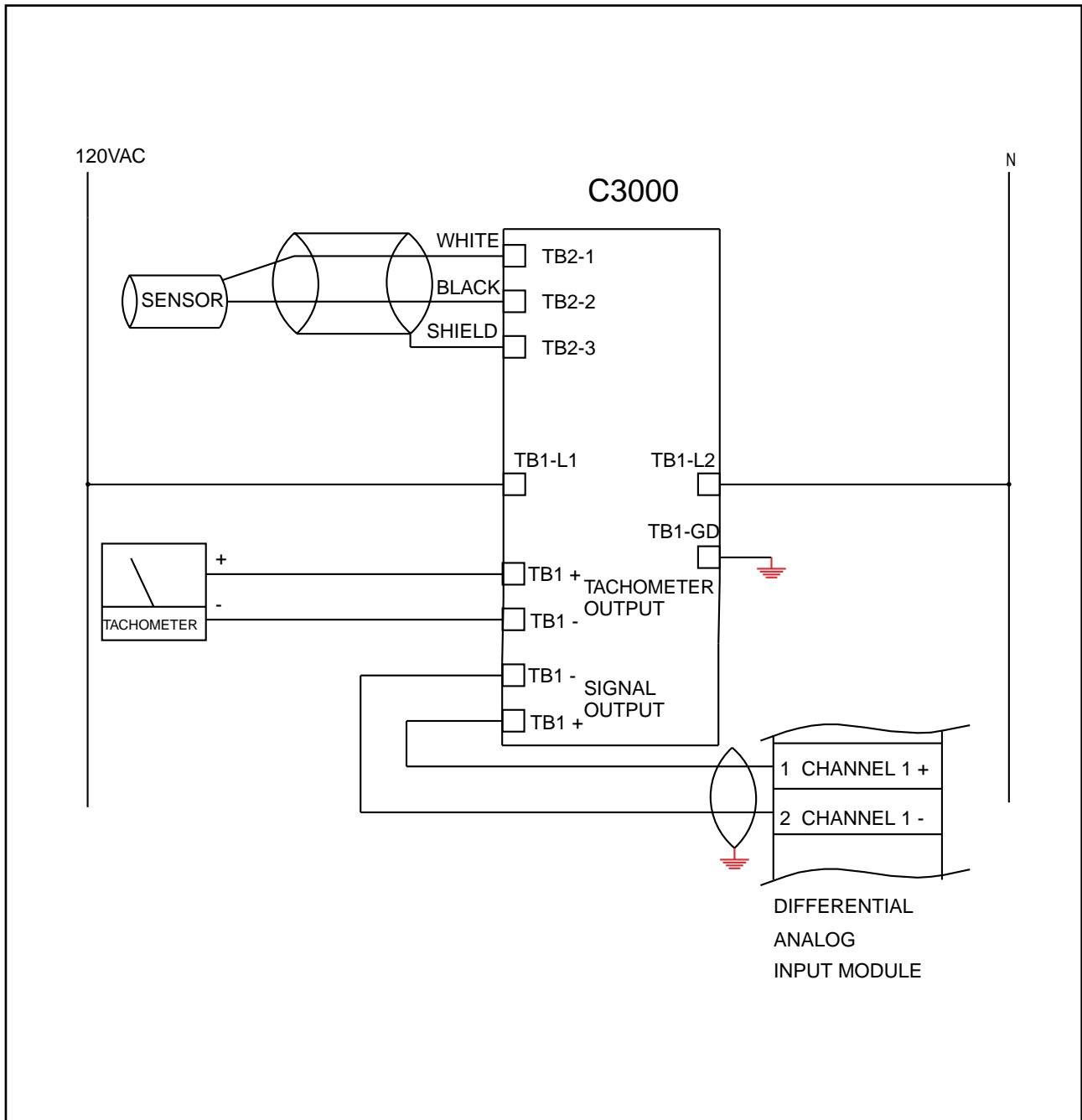

Figure 5

SECTION #3 - FIELD CALIBRATION

7.0 Speed Range Selection

- 7.1 Locate dip switch SW1 on the C3000 circuit board.
(see figure 4, page 5)
- 7.2 Configure the dip switches for the proper speed range based on the maximum shaft speed that the C3000 will be monitoring. Make this selection before calibrating the signal output.
(see figure 6, page 7)

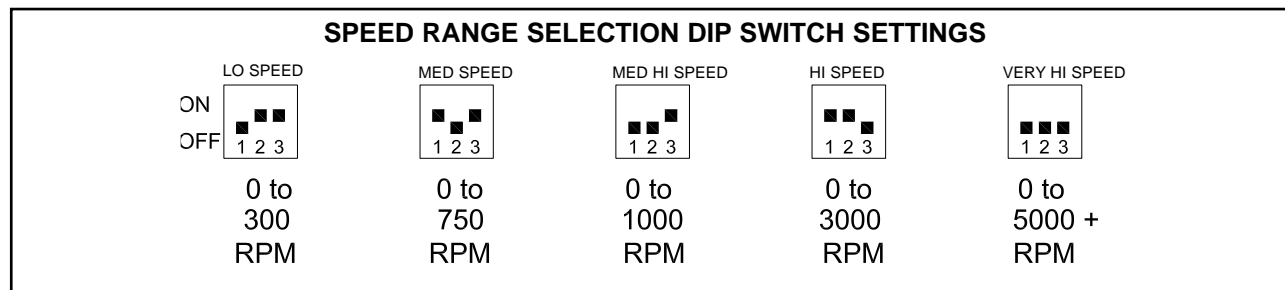

Figure 6

8.0 Output Signal Calibration (4/20 MA or 0-10 VDC)

- 8.1 Locate jumpers J1 and J2 on the C3000 circuit board.
(see figure 4, page 5)
- 8.2 Configure the jumper pins for 4-20 MA or 0-10 VDC.
(see figure 7, page 7)

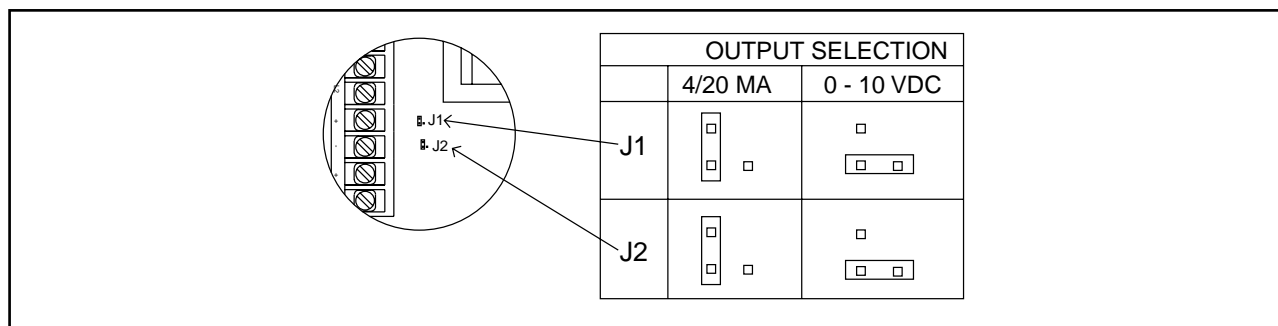

Figure 7

9.0 Zero Adjustment

- 9.1 Apply 120 VAC power to the C3000 circuit board.
- 9.2 Connect a digital meter to + - signal output terminal on terminal block TB1. If using the 4-20 MA scale adjust potentiometer P2 to 4 MA. If using the 0 -10 VDC scale adjust potentiometer P2 to 0 VDC. CW to increase signal CCW to decrease signal.
(see figure 4, page 5)

10.0 Span Adjustment

- 10.1 Apply 120 VAC power to the C3000 circuit board. Run the machine at maximum operating speed (speed that you want to equal full scale).
- 10.2 Connect a digital meter to + - signal output terminal on terminal block TB1. If using the 4-20 MA scale adjust potentiometer P3 to 20 MA. If using the 0 -10 VCD scale adjust potentiometer P3 to 10 VDC. CW to increase signal CCW to decrease signal.
(see figure 4, page 5)
- 10.3 Repeat steps 9.0 to 10.2.

11.0 Optional Tachometer Calibration

- 11.1 Connect display meter to + - tachometer output on terminal block TB1.
- 11.2 Apply 120 VAC power to the C3000 circuit board. Run the machine at normal operating speed.
- 11.3 With the machine running at normal operating speed adjust potentiometer P1 until the meter matches machine speed or rate. CW to increase CCW to decrease.
(see figure 4, page 5)

SPARE PARTS LIST

Part No.	Description
1243	Circuit Board
1129	Sensing Head, w/10' Cable (std) Analog
1130	Mounting Bracket w/Jam Nuts (std)
1132	Sensing Head w/10' Cable (XP) Analog
1134	Mounting Bracket (XP)
1136	Magnet Disc (4" dia)
1378	Magnet Disc (8" dia)

WARRANTY

Process Control Systems, Inc. will repair or replace, at their option, F.O.B. factory, any part or unit which proves to be defective in material or workmanship within five years of purchase date, provided that part of the unit was installed and operated as recommended, to be established by examination of the part or unit at the factory. Goods returned under warranty must be shipped prepaid to the factory and accompanied by the serial number, description of defect, order number and date of purchase.

This warranty shall not apply to any Maxigard™ product which shall have been repaired or altered outside of the Process Control Systems factory or has been subject to misuse, negligence or accident.

Process Control Systems, Inc. warrants its products, but not their application, and shall not be liable for any incidental or consequential damages incurred through the use or loss of use of a Process Control Systems product. No representatives or other person is authorized or permitted to make any warranty or assume for this company any liability not strictly in accordance with this guarantee.

There is no further warranty either expressed or implied beyond that set forth herein.